

## Acterna ANT-20 Advanced Network Tester – SONET/SDH

The flexible, high performance test platform



# Equipped to meet the challenges of advanced network testing

In the fiercely competitive telecommunications arena, technological and economic excellence is crucial to commercial success. Acterna, with its firm commitment to sustained leadership in all aspects of the communications network life cycle, is dedicated to helping customers rise to the market's challenges in order to ensure economic value in their businesses.

- Delivers SONET and SDH testing from 1.5 Mbps to 10 Gbps and DSn, ATM and PDH testing
- Provides jitter/wander measurements up to OC-192/STM-64

With technologies developing rapidly the Acterna ANT-20 advanced network tester is designed to meet customers' future needs. This flexible platform enables customers to adapt to technological change and can accommodate the DSn, SONET, SDH and/or ATM requirements, as well as new standards, higher bit rates and the intelligent system components of the future.

The ANT-20 is suitable for a number of applications including development labs, conformance and functional tests in production, installation and acceptance and can help pinpoint potential problems within in-service networks. The highly flexible measurement capabilities of the ANT-20 make it possible to investigate all major quality parameters on diverse interfaces, ranging from simple bit error rate tests (BERT) to performance and pointer analysis, covering even complex synchronization problems. The ANT-20 offers a customizable test solution that can be tailored to specific individual needs.

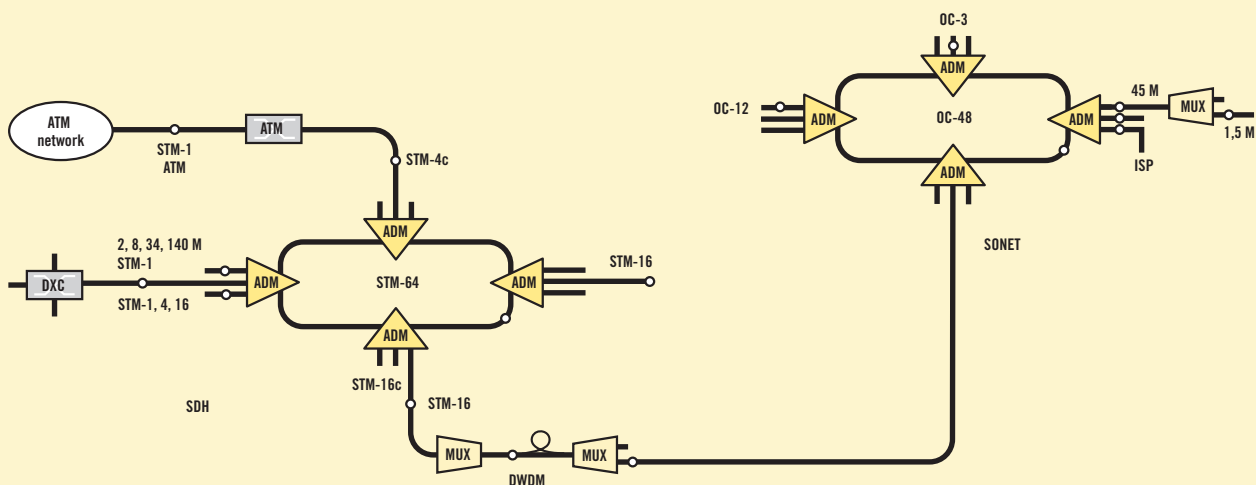
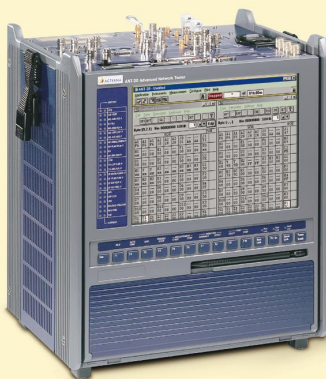

A comprehensive platform for monitoring all network test points

# Ease of use within a familiar work environment

Acterna works closely with systems manufacturers and network operators to define new quality standards and guarantee optimum ease of use. From detailed parameter settings and test results, to simple operation for DS<sub>n</sub>, SONET, SDH with all bit rates from 1.5 Mbps to 10 Gbps and ATM, the ANT-20 delivers sophisticated, precise test capabilities that can be used for all the above bit rates as well as ATM.

## Clear results

All results can be viewed at a glance, either numerically as a complete list of error values, or graphically as a histogram. The zoom function is useful for examining results from a longer test interval with various resolutions. The day or hour resolution provides an overview whilst the minute or second resolution enables analysis of critical phases. To ensure accuracy, the duration of all alarms is saved with 100 ms resolution.

## Familiar environment

The ANT-20's built-in PC with its Windows-based design makes integration and use of the instrument in various work environments simple and easy. Test results can be saved internally in the ANT-20 or on diskette and printed in report format on any standard printer. PC software such as Microsoft Excel™ or Word™ can also be used for documentation purposes. The ANT-20's built-in help functions are easily accessible, delivering answers and technical information directly to the user.

## Large color touchscreen

The large color touchscreen is ideal for field use and gives a structured overview of all test results thus helping prevent faulty settings. Several windows may remain open at once in order to access information at-a-glance without the need to switch between menu screens.

## Simple operation with instant access keys

Instant access keys enable direct and speedy launch of the ANT-20 with the user's most often-selected settings. This reduces the time and cost associated with taking the same measurements repeatedly, as occurs during installation and acceptance of SONET/SDH networks. The design of the ANT-20 allows an almost unlimited number of instrument settings to be stored. Customization features enable eight preferred applications to be launched directly from the ANT-20 desktop. Individual keys can be linked to a number of functions and options including stored settings for the ANT-20 or CATS Test Sequencer, the user manual – stored in PDF format – or other frequently needed documents. The ANT-20 is able to perform measurements using predefined settings at the touch of a button.

## Acterna ANT-20

### *Compact for field work*

Free slot for OC-48/STM-16 or jitter up to 622 Mbps. SONET and SDH mappings, even in combination with ATM realtime analysis work on SONET/SDH/DS<sub>n</sub> interfaces from 1.5 Mbps to 2.5 Gbps.

## Acterna ANT-20se

### *More in a portable unit*

The ANT-20se is a four-slot solution that offers greater functionality than the ANT-20 and is prepared for future combinations of different tests. Combination and parallel operation of ATM and all bit rates up to OC-48/STM-16 with jitter/wander is possible in this single unit.

## Acterna ANT-10G

### *Equipped for future developments*

With its OC-192/STM-64 optical interface, ANT-10G extends the capabilities of the ANT-20se to handle the higher bit rates of 10-Gbps systems. Access to all common interfaces from 1.5 Mbps to 10 Gbps is possible and all standardized mappings are covered. The solution also offers an integrated state-of-the-art jitter and wander test module.

# Modular design allows user customization

## SONET OC-48/SDH STM-16

Electrical and optical interfaces for 2.488 Mbps

## ATM BAG

Easy to operate broadband analyzer/generator (BAG) module with ATM test controller for accepting, installing, testing and maintaining ATM systems on switched and permanent virtual connections (SVC)

## Jitter/wander at OC-48/STM-16

Jitter/wander generation and analysis at 2.488 Mbps as per ITU-T O.171 and O.172

## SONET OC-192/SDH STM-64

Electrical and optical interfaces for 9.953 Mbps and integrated jitter/wander generation and analysis as per ITU-T O.171 and O.172

## DSn/SONET up to OC-12 and PDH/SDH up to STM-4

Electrical and optical interfaces for both SONET/DSn and SDH/PDH (fixed module, various configurations possible)



## High-performance computer

High-performance computer built into ANT-20 (fixed module) with mouse port, PCMCIA interfaces A and B, external keyboard port, external monitor port, external printer port and RS-232 interface

## Jitter/wander up to OC-12/STM-4

Jitter/wander generation and analysis at all bit rates up to 622 Mbps as per ITU-T O.171 and O.172

## Power splitter

Optical power splitter for external protected monitor point

# Innovative functions offer ideal support

The ANT-20 contains everything needed for network optimization and can be used in a number of application areas including:

## Assurance of correct APS operation

Delayed ring switching can lead to entire ring spans or even whole rings being taken out of operation. The ANT-20 simplifies measurement of the switchover time from working line to protection line. Should a fault occur, the instrument provides detailed analysis of the APS protocol procedures delivering immediate detection of faulty commands.

## Assessment of quality on OC-192c and STM-64c lines

OC-192c and STM-64c can now be used to provide uniform bandwidths for IP and ATM. The previous limit of approximately 2.4 Gbps was implemented using OC-48c (2.5 Gbps with SDH STM-16c). OC-192c and STM-64c quadruple the payload capacity to approximately 10 Gbps (9.6 Gbps for STM-64c). This technology is used primarily to link high-speed data networks.

However, large bandwidth becomes ineffective if data packets are continually retransmitted due to transmission errors. The ANT-20 supports this new technology by helping to pinpoint problems quickly. When equipped with the OC-12c/STM-4c, OC-48c/STM-16c and OC-192c/STM-64c options, the ANT-20 becomes a full-featured concatenation tester.

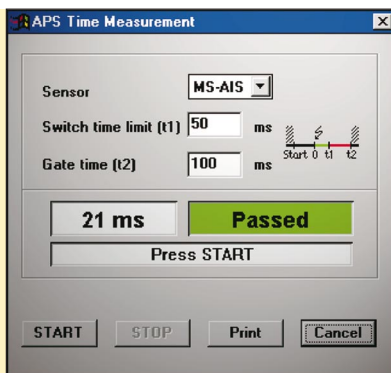

Sample results from a switchover time measurement

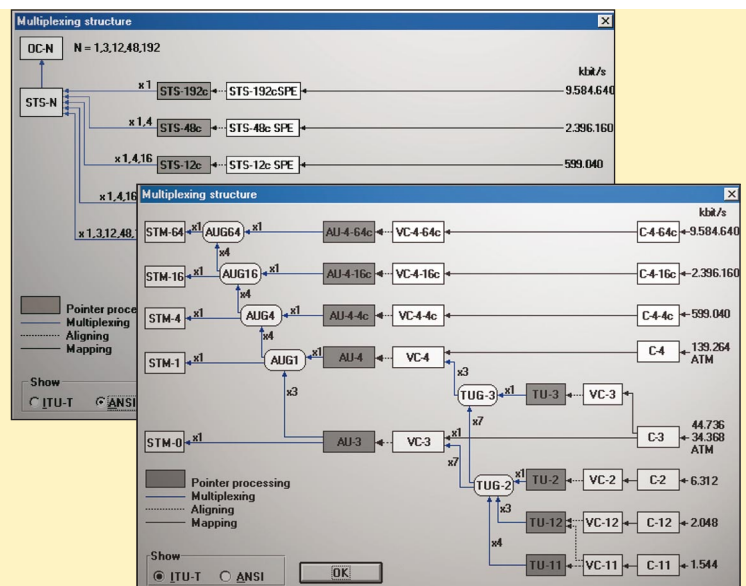

Test executions and results analysis for SONET and SDH

**Save time and avoid errors with automatic test functions**

To assist technicians with commonly encountered issues such as unknown signal structure, the ANT-20 provides automatic test modes to simplify test startup and provide a fast overview of four-channel systems. Multistage analysis allows the status of individual channels to be viewed at the click of the mouse.

<b>Autoconfiguration</b>	Searches for signal and unknown content
<b>SCAN</b>	Tests for error-free connection of all SONET channels
<b>Trouble SCAN</b>	Checks all incoming SONET channels for errors/alarms
<b>Search</b>	Searches for test channels in SONET signals
<b>Auto SCAN</b>	Analyzes the structure of an SONET signal up to OC-192

**Check and optimization of quality of service (QoS) in ATM networks**

The ANT-20 effectively tests ATM networks and/or network elements (NE) for correct operation and QoS. Depending on the application, the ANT-20 also has test solutions for permanent virtual circuits (PVC) as well as switched virtual circuits (SVC).

Major applications include:

- Signaling emulation as per ATM Forum UNI 3.0/3.1 and ITU-T Q.2931/Q.2961 SVC and PVC testing
- Automatic end-to-end testing of SVCs
- Realtime measurement of ATM QoS on four channels simultaneously
- Testing of all traffic contract parameters
- ATM terminal simulation for dial-up circuits
- Graphical evaluation using load charts

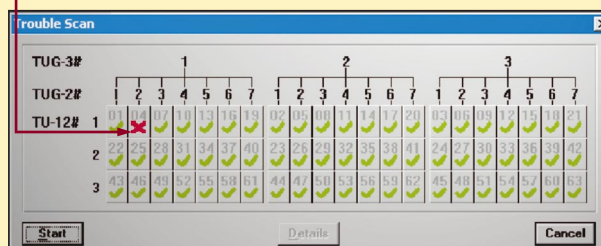
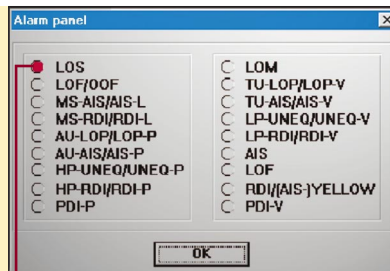

Trouble Scan

## Simple remote operation, interactive or fully automated

Remote operation is easy with ANT-20 requiring just a laptop and modem or LAN connection. The Windows-based design of the ANT-20 allows the same software and identical user interface to be run and displayed on the instrument and the laptop software installed on ANT-20 like the Acterna CATS Test Sequencer can therefore be operated remotely allowing complicated, time-consuming tests to be conducted easily from the office or home.

Time saving applications include:

- Operation of several ANT-20s from a central office; ideal for point-to-point measurements for example
- Assistance with on-site test problems *A specialist in the main office can monitor the ANT-20's user interface and advise the local operator on how to solve the problem(s)*
- Perform interactive measurements or test sequences
- An external test point scanner is used to switch between prepared test points from any location at any time

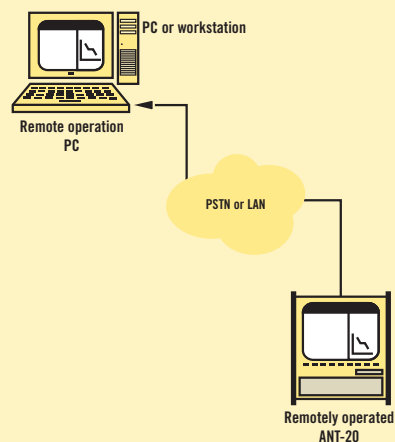

Remote operation of the ANT-20

# Automated test sequences with reproducible results

## Save time and money through automation

The Acterna CATS\* Test Sequencer – a test-automation software package that runs on the ANT-20’s built-in PC – is the ideal tool for automating repetitive test procedures. It provides support in handling standard tests, enabling users with little or no programming background to create test sequences for their own specific needs. A number of predefined, user-modifiable test steps are provided for immediate use. Test automation is particularly important when commissioning NEs and/or lines. The various measurements can be performed in sequence and documented.

The ANT-20 CATS Test Sequencer is an effective tool for acceptance measurements as well as the development and production of NEs.

Once created, a test sequence can be recalled at any time. Each run of a sequence generates a file with all result data and a clear PASS/FAIL for each test step and the overall sequence.

### Sample test sequence for commissioning 2 Mbps leased lines

<b>Basic settings</b>	TX 2 Mbps	Set TX signal structure
	RX 2 Mbps	Set RX signal structure
<b>Test of parameters</b>	View alarm	Check for no alarms
	Continuity check	BERT in channel
	Pulling range	Check pulling range (offset)
	Check LOS	Set LOS, wait for AIS
	Jitter measurement	Measure intrinsic jitter
	Jitter tolerance	Measure jitter tolerance
	Delay measurement	Measure signal delay
<b>Test end</b>	G.826 Analysis (for SONET)	G.826 Analysis, 24 h
	Thank you	End of test

\*CATS CVI application test sequencer

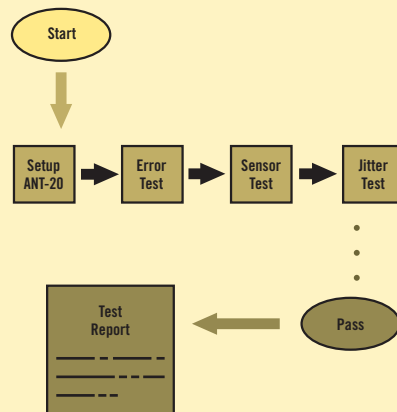

Execution of a typical test sequence



# A reliable solution for jitter and wander

## Tight standards for synchronization

Higher bit rates, combined with synchronous technology demand greater clock quality within networks. For quality assurance purposes, international standards have defined stringent limits for jitter and wander. Precision equipment can test whether the outgoing clock quality meets these standards and how NEs respond to poor clock quality.

## A comprehensive solution for jitter and wander

The ANT-20 can generate and analyze jitter and wander for bit rates from 1.5 Mbps to 9.953 Mbps and is fully compatible with ITU-T recommendation O.172, making the instrument the ideal solution for handling diverse tests and delivering informative, comparable, precise results. The following parameters can be measured:

- Output jitter
- Maximum tolerable jitter (MTJ)
- Jitter transfer function (JTF)
- Mapping and pointer jitter (combined jitter)
- Peak-to-peak jitter, RMS jitter, and jitter vs. time
- Wander generation and analysis
- Maximum time interval error and time deviation (MTIE/TDEV) offline analysis
- Maximum tolerable wander (MTW)

## Additional functions to keep you ahead

A range of additional functions allow the ANT-20 to perform fast, reliable wander analysis with results reflecting:

- Time interval error (TIE)
- MTIE, based on TIE data
- MTIE/TDEV offline analysis can be used to evaluate wander results measured and stored by the ANT-20 the results of which can be displayed graphically and compared with standardized masks.

All jitter and wander applications can be automated using the CATS Test Sequencer as jitter tests are an important component of acceptance procedures.

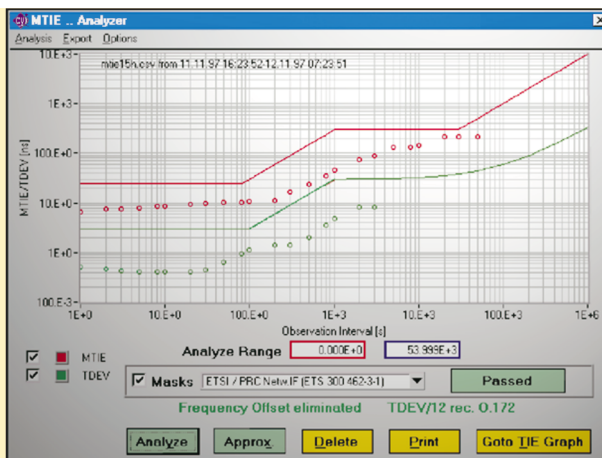

Display of MTIE/TDEV results and comparisons against masks

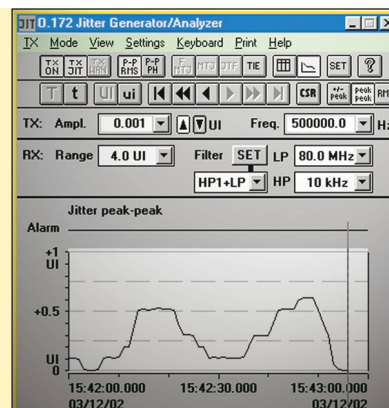

The jitter vs. time display provides an excellent overview of how the output jitter varies over time

# A pacesetter for the future

Recent years have seen a dramatic increase in the trend towards global interconnection with the Internet fueling this growth. To meet new bandwidth requirements, two technologies predominate: time division multiplexing (TDM) of synchronous channels which is used to transmit higher bit rates, and dense wavelength division multiplexing (DWDM) which makes use of the different optical windows on a fiber. Both technologies are employed to optimize the use of existing optical fiber capacity.

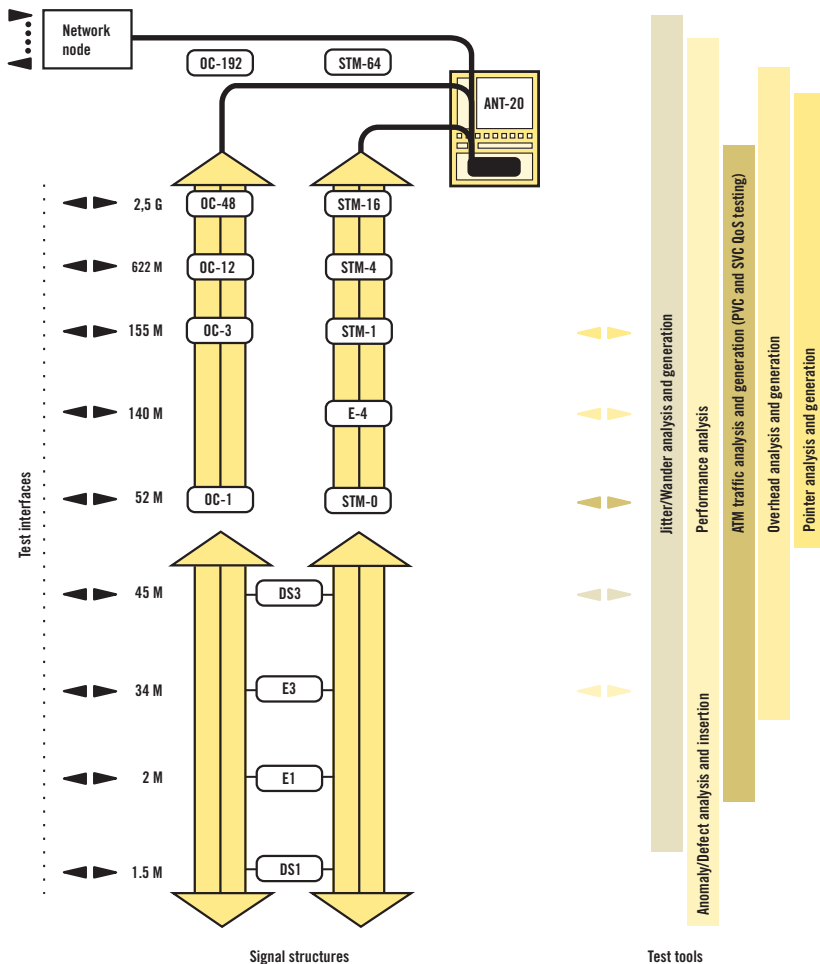

Even at 10 Gbps, ANT-20se can break down signal structures and analyze them down to the lowest levels

**USED4TEST**

Телефон: +7 (499) 685-7744

used@used4test.ru

www.used4test.ru